

VL 25G

vertical multi-stage pumps



Robust vertical multi-stage pumps in stainless steel, distinguished by their high efficiency and particularly quiet operation.

RANGE OF PERFORMANCE

Flow rate up to 34 gpm
Head up to 296 ft

LIMITS OF USE

Manometric suction lift up to 23 ft
Liquid temperature up to 104°F

CONSTRUCTION AND SAFETY STANDARDS

EN 60 335-1	EN 60034-1
IEC 335-1	IEC 34-1
CEI 61-150	CEI 2-3



INSTALLATION AND USE

They are recommended for pumping clean water and liquids that are chemically non aggressive to the materials from which the pump is made.

THEIR RELIABILITY AND QUIET RUNNING MAKE THEM SUITABLE FOR DOMESTIC AND CIVIL APPLICATIONS, BECAUSE THE PUMP IS FULLY SUBMERSIBLE WITH THE MOTOR COOLED BY THE PUMPED LIQUID, IT CAN BE USED SAFELY IN WET ENVIRONMENTS AND IN SPACES WITH INSUFFICIENT VENTILATION.

GUARANTEE 2 YEARS subject to our general terms of sale.

CONSTRUCTION CHARACTERISTICS

- **OUTER CASE AND MOTOR SUPPORT:** stainless steel AISI 304 case with threaded ports.
- **IMPELLERS AND DIFFUSERS:** technopolymer.
- **DIAPHRAGMS:** stainless steel AISI 304, complete with anti-wear rings.
- **MOTOR SHAFT:** stainless steel EN 10088-3 - 1.4104.
- **DOUBLE SEAL:** mechanical seal silicon carbide-NBR, with oil barrier chamber and inner lip seal to protect the seal in the event of dry running.
- **SCREWS:** stainless steel AISI 304.
- **MOTOR:** electric, asynchronous for continuous duty.
VL 25G: single-phase 230V - 60 Hz with thermal overload protector built into windings below 1.5 Hp. The 2 Hp motor has an external overload protector (with manual reset) incorporated into the control box.
- **VL 25G:** three-phase 230V - 60 Hz.
- **INSULATION:** class F. • **PROTECTION:** IP 68.

STANDARD FEATURES:

VL 25G (single-phase) 6 ft power cable type "H07 RN-F" with removable connector.
Control box with capacitor.

VL 25G (three-phase) 6 ft power cable type "H07 RN-F" with removable connector.

OPTIONS ON REQUEST

⇒ other voltages or frequency 50 Hz

CURVES AND PERFORMANCE DATA

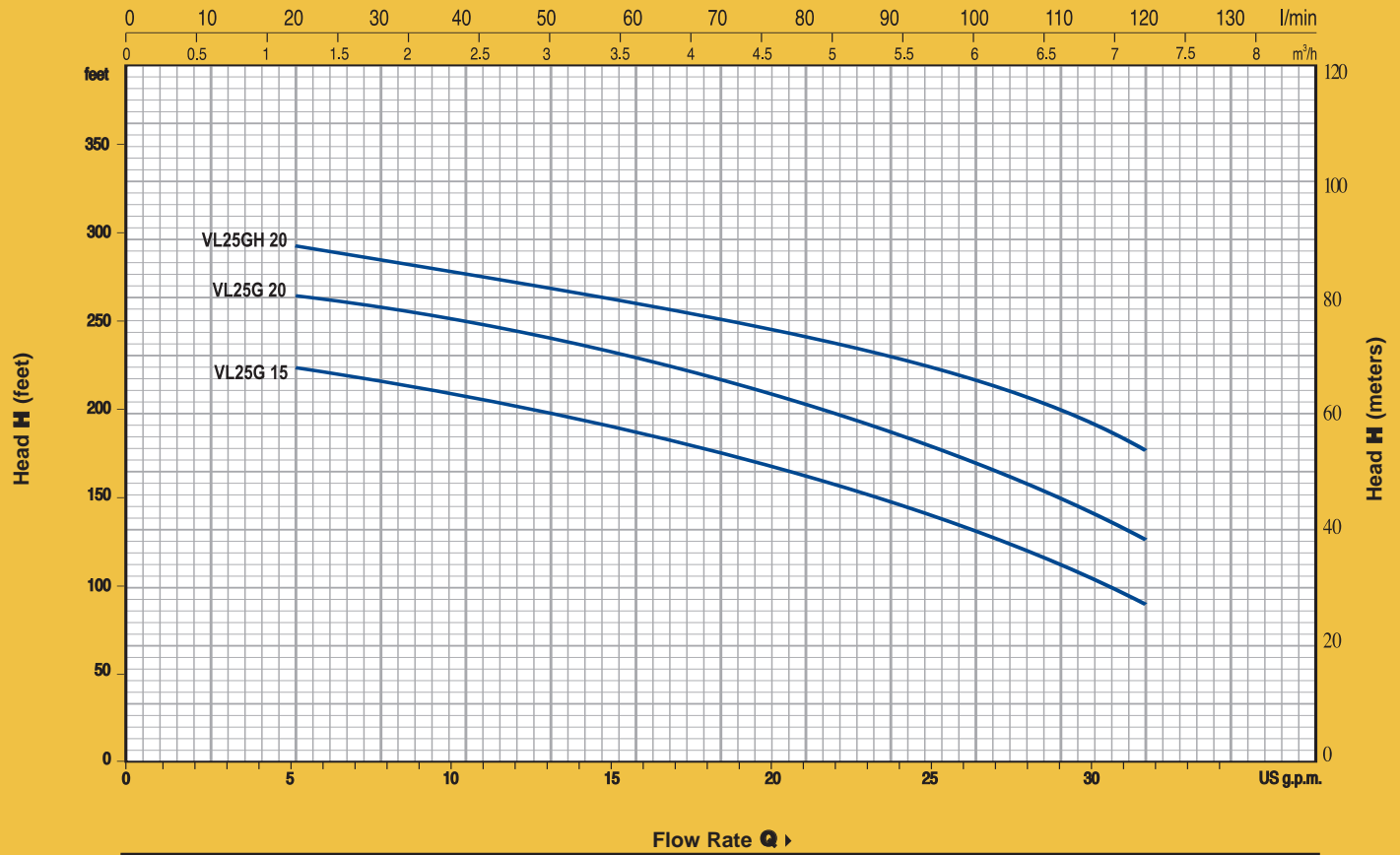

MODEL		HP	FLOW RATE GPM															
1 PH	3 PH		0	2	5	7	10	13	15	18	21	23	26	29	31	34		
VL25G 15		1.5	0	10	20	30	40	50	60	70	80	90	100	110	120	130		
VL25G 20	VL 25G 20	2.0	H Feet															
VL25GH 20	VL 25GH 20	2.0	223	220	217	210	204	195	187	176	164	151	135	122	105	89		
			263	260	253	246	240	233	223	214	204	191	177	161	145	125		
			296	292	289	283	276	269	263	253	246	237	223	210	195	177		

DIMENSIONS AND WEIGHT

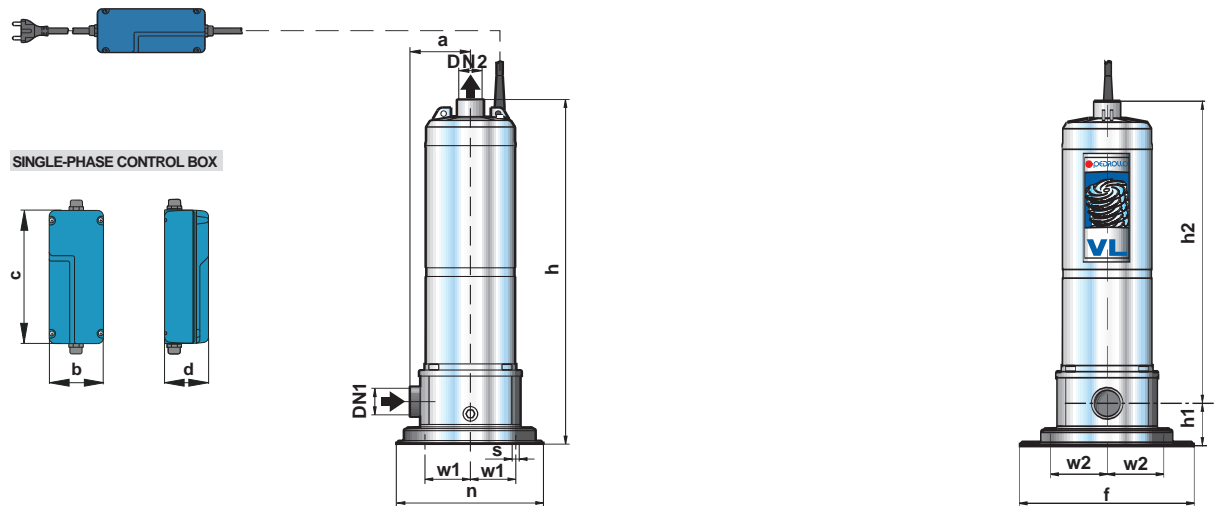

MODEL		SUCTION / DISCH			DIMENSIONS INCHES													LBS		
1 PH	3 PH	DN1	DN2	No STAGES	a	b	c	d	f	h (1~)	h (3~)	h (1)	h2(1~)	h2(3~)	n	w1	w2	s	1~	3~
VL25G15				4						22.5			20.1						50.8	
VL25G 20	VL25G 20	1 1/2"	1 1/4"	5	125.4	106.4	225.4	91.4	248.4	23.7	23.7	2.3	21.3	21.3	7.2	2.4	3.4	0.4	53.3	49.5
VL25G H20	VL25G H20			4						25.5	22.5		23.1	20.1					63.9	51.3