

PNGA

stainless steel pumps

Centrifugal pumps made of stainless steel AISI 316, equipped with an open impeller, ideal for transferring liquids containing impurities.



RANGE OF PERFORMANCE

Flow rate up to 92 gpm
Head up to 66 ft

LIMITS OF USE

Manometric suction lift up to 23 ft
Liquid temperature up to + 194°F
Environment temperature up to + 104°F
Passage of solid bodies Ø 4/10"

CONSTRUCTION AND SAFETY STANDARDS

EN 60034-1
IEC 34-1
CEI 2-3



INSTALLATION AND USE

They are recommended for pumping water and liquids that are chemically non aggressive to the materials from which the pump is made.

THE OPEN IMPELLER DESIGN ALLOWS THE PUMPING OF LIQUIDS WITH RELATIVELY HIGH LEVELS OF IMPURITIES WITHOUT RISK OF CLOGGING THE IMPELLER. FOR THIS REASON THE PRO-NGA SERIES ARE SUITABLE FOR USE IN SYSTEMS FOR WASHING FRUIT, VEGETABLES, FISH, SHELLFISH, MEAT, IN INDUSTRIAL SYSTEMS FOR WASHING METAL PARTS, GLASS CONTAINERS, AND FOR THE CIRCULATION OF COOLING LIQUIDS.

The pumps must be installed in enclosed places, or at least protected against inclement weather.

GUARANTEE 2 YEARS subject to our general terms of sale.

CONSTRUCTION CHARACTERISTICS

- **PUMP BODY:** stainless steel AISI 316, with threaded ports.
- **BODY BACK-PLATE:** stainless steel AISI 316.
- **OPEN IMPELLER:** stainless steel AISI 316.
- **MOTOR SHAFT:** stainless steel AISI 316.
- **MECHANICAL SEAL:** ceramic - graphite - viton - AISI 316
- **ELECTRIC MOTOR:** the pumps are close-coupled to a carefully matched PEDROLLO electric motor, quiet running, totally enclosed fan cooled (TEFC), suitable for continuous duty.
PNGA: single-phase 115 V or 230 V - 60 Hz with capacitor and thermal overload protector.
PNGA: three-phase 230/460 V - 60 Hz.
- **INSULATION:** class F. • **PROTECTION:** IP 44.

OPTIONS ON REQUEST

- ⇒ special mechanical seal
- ⇒ other voltages or frequency 50 Hz
- ⇒ protection IP 55

CURVES AND PERFORMANCE DATA

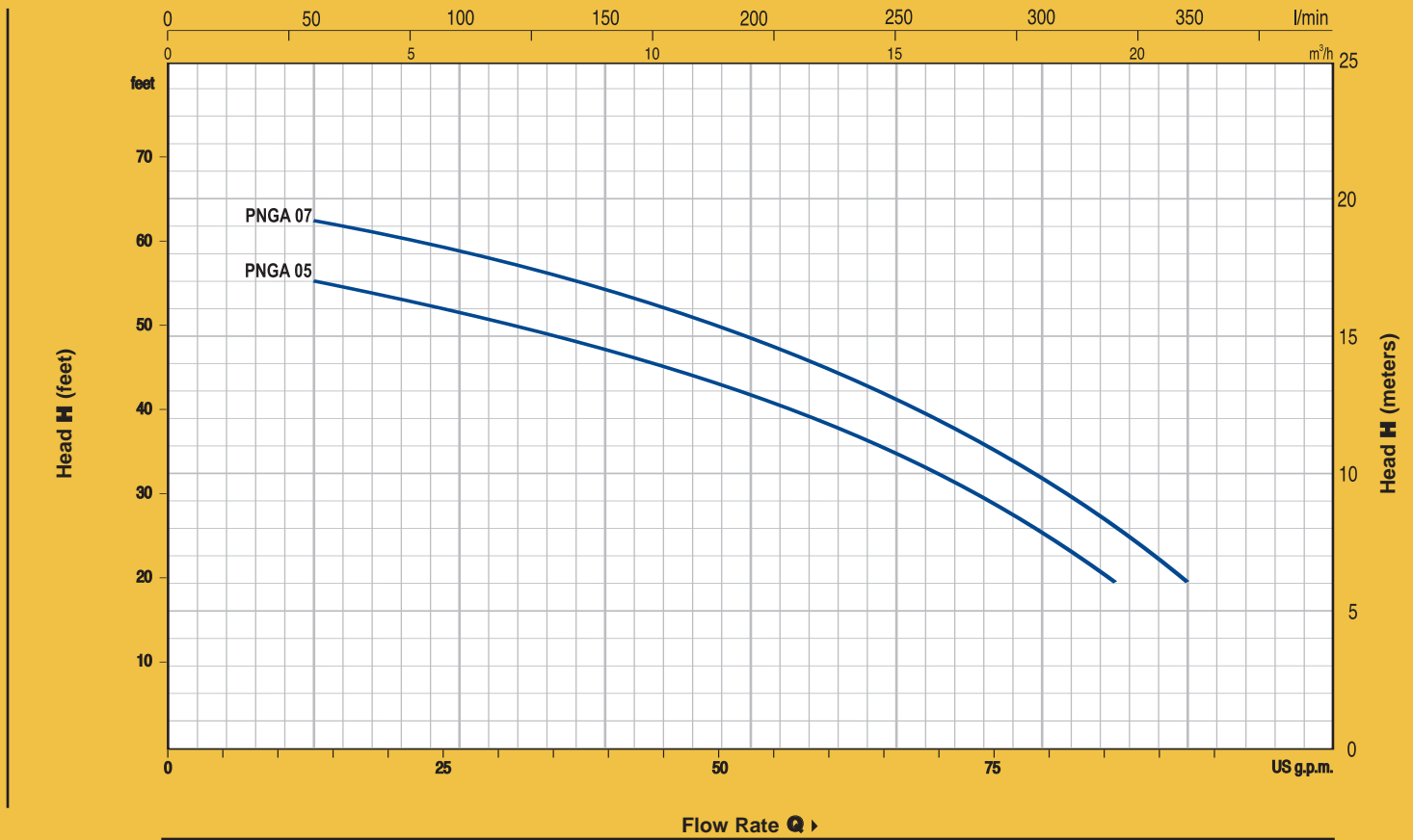

MODEL		HP	FLOW RATE GPM									
1 PH	3 PH		0	13	26	39	52	66	79	86	92	
PNGA 05	PNGA 05	0.5	H Feet									
PNGA 07	PNGA 07	0.7	59	56	53	48	43	34	26	20	20	

DIMENSIONS AND WEIGHT

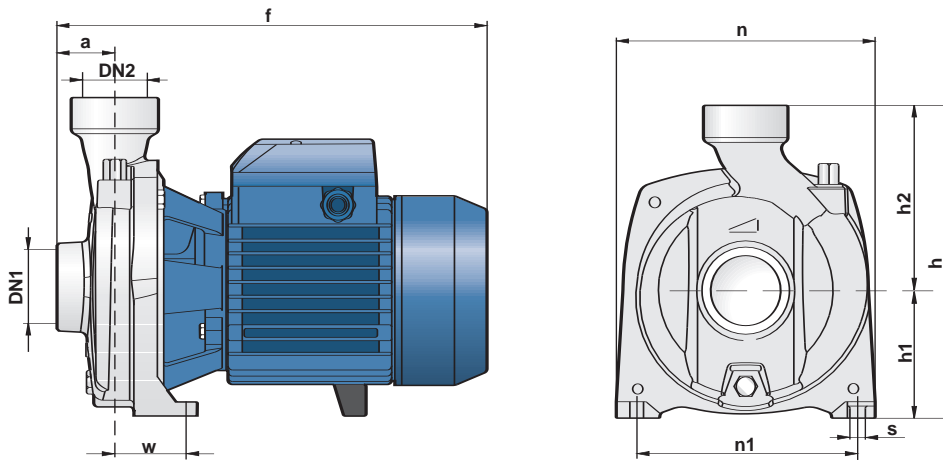

MODEL		SUCTION /DISCH		DIMENSIONS INCHES										LBS	
1 PH	3 PH	DN1	DN2	a	f	h	h1	h2	n	n1	w	s	1~	3~	
PNGA 05	PNGA 05	1 1/2"	1 1/2"	1.6	11.7	8.9	3.6	5.3	7.5	6.3	2.0	0.4	28.7	26.5	
PNGA 07	PNGA 07	1 1/2"	1 1/2"	1.6	11.7	8.9	3.6	5.3	7.5	6.3	2.0	0.4	29.0	26.7	