



RANGE OF PERFORMANCE

Flow rate up to 13 gpm
Head up to 330 ft

LIMITS OF USE

Manometric suction lift up to 29 ft
Liquid temperature up to + 140°F
Environment temperature up to + 104°F

CONSTRUCTION AND SAFETY STANDARDS

EN 60034-1
IEC 34-1
CEI 2-3



INSTALLATION AND USE

They are recommended for pumping clean water without abrasive particles and liquids that are chemically non aggressive to the materials from which the pump is made.

FOR THEIR COMPACTNESS, RELIABILITY AND ECONOMY THEY ARE SUITABLE FOR DOMESTIC USE AND IN PARTICULAR FOR DISTRIBUTING WATER IN COMBINATION WITH SMALL PRESSURE SETS, FOR IRRIGATING GARDENS, DRAWING WATER FROM TANKS OR WELLS DOWN TO A DEPTH OF 27 FEET AND IN ALL CASES WHERE THERE IS THE PRESENCE OF AIR OR GAS IN THE LIQUID TO BE PUMPED; the pump is provided with a check flap valve on the intake so that it is no longer necessary to fit a foot valve. The pumps must be installed in enclosed places, or at least protected against inclement weather.

GUARANTEE 2 YEARS subject to our general terms of sale.

CONSTRUCTION CHARACTERISTICS

- **PUMP BODY:** cast iron, with threaded ports.
- **CHECK FLAP VALVE:** incorporated in the suction port.
- **MOTOR BRACKET (patent n° 1289150):** aluminium with brass insert; reduces starting difficulties due to seizure of the impeller after long periods of inactivity.
- **IMPELLER:** brass, of the type with radial peripheral vanes.
- **MOTOR SHAFT:** stainless steel EN 10088-3 - 1.4104.
- **MECHANICAL SEAL:** ceramic - graphite - NBR.
- **ELECTRIC MOTOR:** the pumps are close-coupled to a carefully matched PEDROLLO electric motor, quiet running, totally enclosed fan cooled (TEFC), suitable for continuous duty.

PKS: single-phase 115 V or 230 V - 60 Hz with capacitor and thermal overload protector.

PKS: three-phase 230/460 V - 60 Hz

- **INSULATION:** class F. ● **PROTECTION:** IP 44.
- **REGISTERED MODEL n° 72753.**

OPTIONS ON REQUEST

- ⇒ special mechanical seal
- ⇒ other voltages or frequency 50 Hz

CURVES AND PERFORMANCE DATA

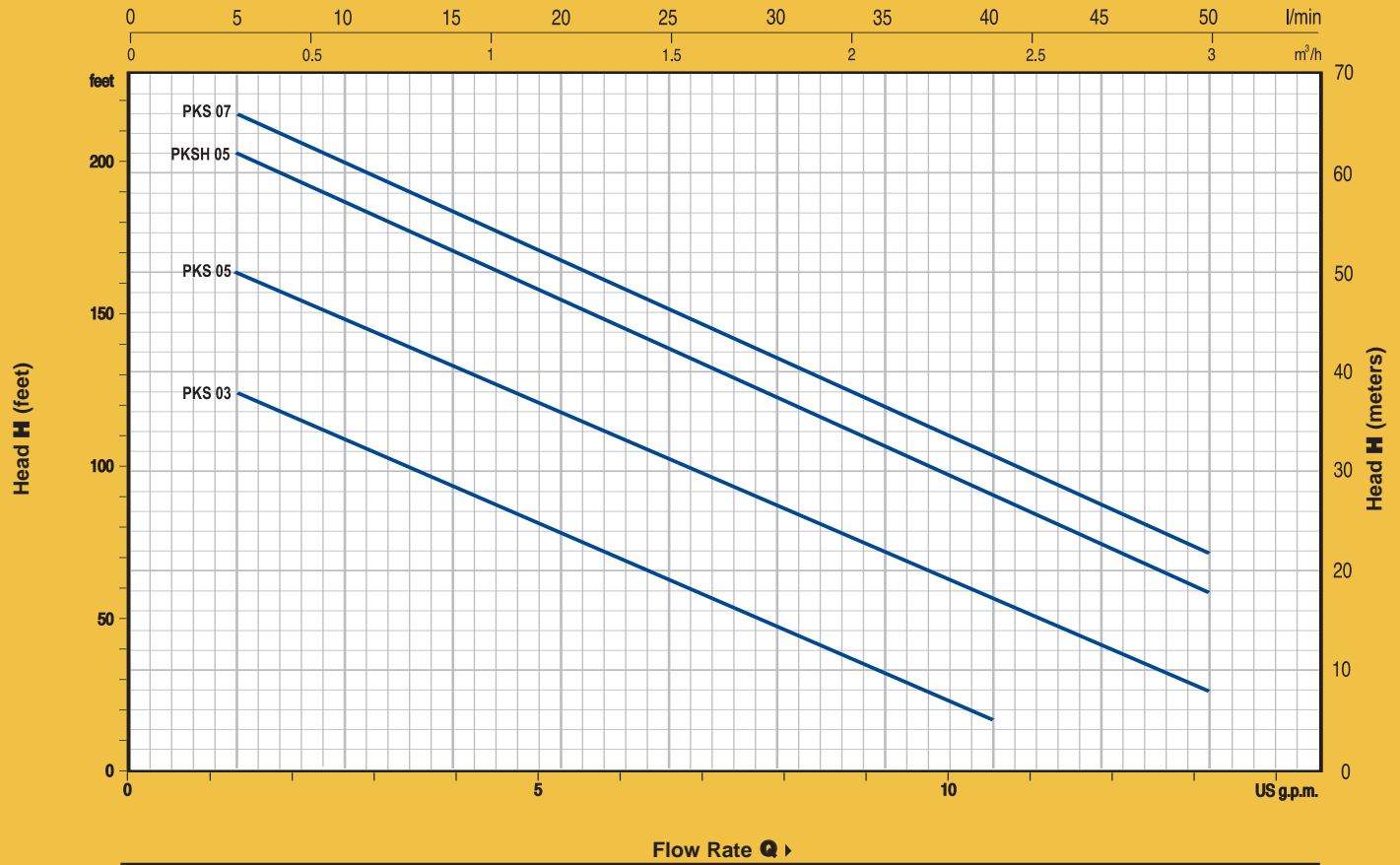

MODEL		HP	FLOW RATE GPM																						
1 PH	3 PH		FLOW RATE l/min																						
PKS 03	PKS 03	0.33	0	1.2	2.7	4	5.5	6.6	8	9.3	10.2	11.9	13.2	H feet	0	5	10	15	20	25	30	35	40	45	50
PKS 05	PKS 05	0.5	131	125	110	95	79	64	49	33	16	180	164		149	133	118	102	89	72	56	41	26		
PKSH 05	PKSH 05	0.5	213	203	187	171	154	138	121	105	89	72	59		230	216	200	184	167	151	134	120	102	89	72
PKS 07	PKS 07	0.7	230	216	200	184	167	151	134	120	102	89	72												

DIMENSIONS AND WEIGHT

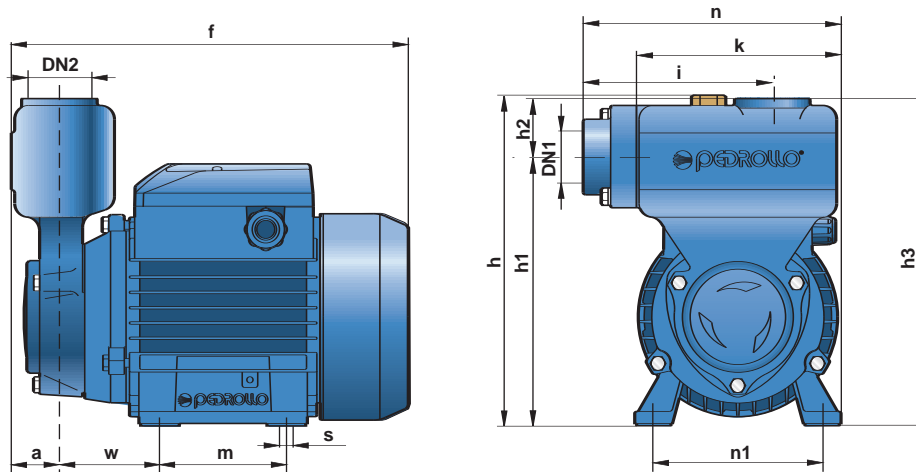

MODEL		SUCTION /DISCH		DIMENSIONS INCHES													LBS	
1 PH	3 PH	DN1	DN2	a	f	h	h1	h2	h3	i	m	n	k	n1	w	S	1~	3~
PKS 03	PKS 03	1"	1"	1.1	9.1	7.5	6.1	1.3	7.4	4.3	3.1	5.9	4.7	3.9	2.1	0.2	13.4	13.4
PKS 05	PKS 05	1"	1"	1.1	9.4/9.0	7.5	6.1	1.3	7.4	4.3	3.1	5.9	4.7	3.9	2.1	0.2	17.0	15.6
PKSH 05	PKSH 05	1"	1"	1.1	10.2	7.8	6.4	1.3	7.7	4.3	3.5	6.2	5.4	4.4	2.4	0.2	23.6	21.2
PKS 07	PKS 07	1"	1"	1.1	10.2	7.8	6.4	1.3	7.7	4.3	3.5	6.2	5.4	4.4	2.4	0.2	23.8	21.4